

DETAIL B  
SCALE 1 : 6

Description	Place	Quantity*
1/4" Wiz	Strike to extension	*5
1/4" Sq.	Sill to "jamb to sill bracket"	2
1/4" TRUSS	Header to Head Jamb	3
5/16" Drive Stud	Jamb to "jamb to sill bracket"	4
3/8" Wiz	Frame to head jamb	4
3/8" Wiz	Strut to sill support	2
3/8" Wiz	Strut to header	4
3/8" Sq.	Sill to sill support	4
ADJ ANCHOR	A	2
ANCHOR	B	2
JACK BOLT	C	4

\*INCREASES WITH TALLER ENTRANCES

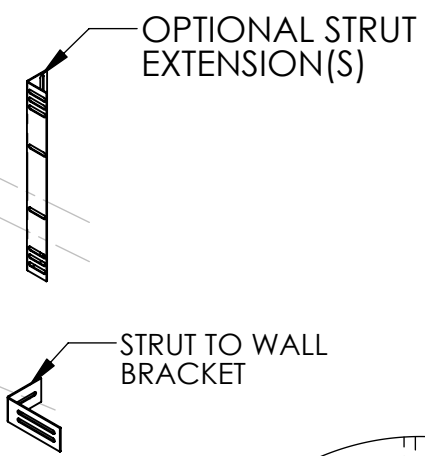
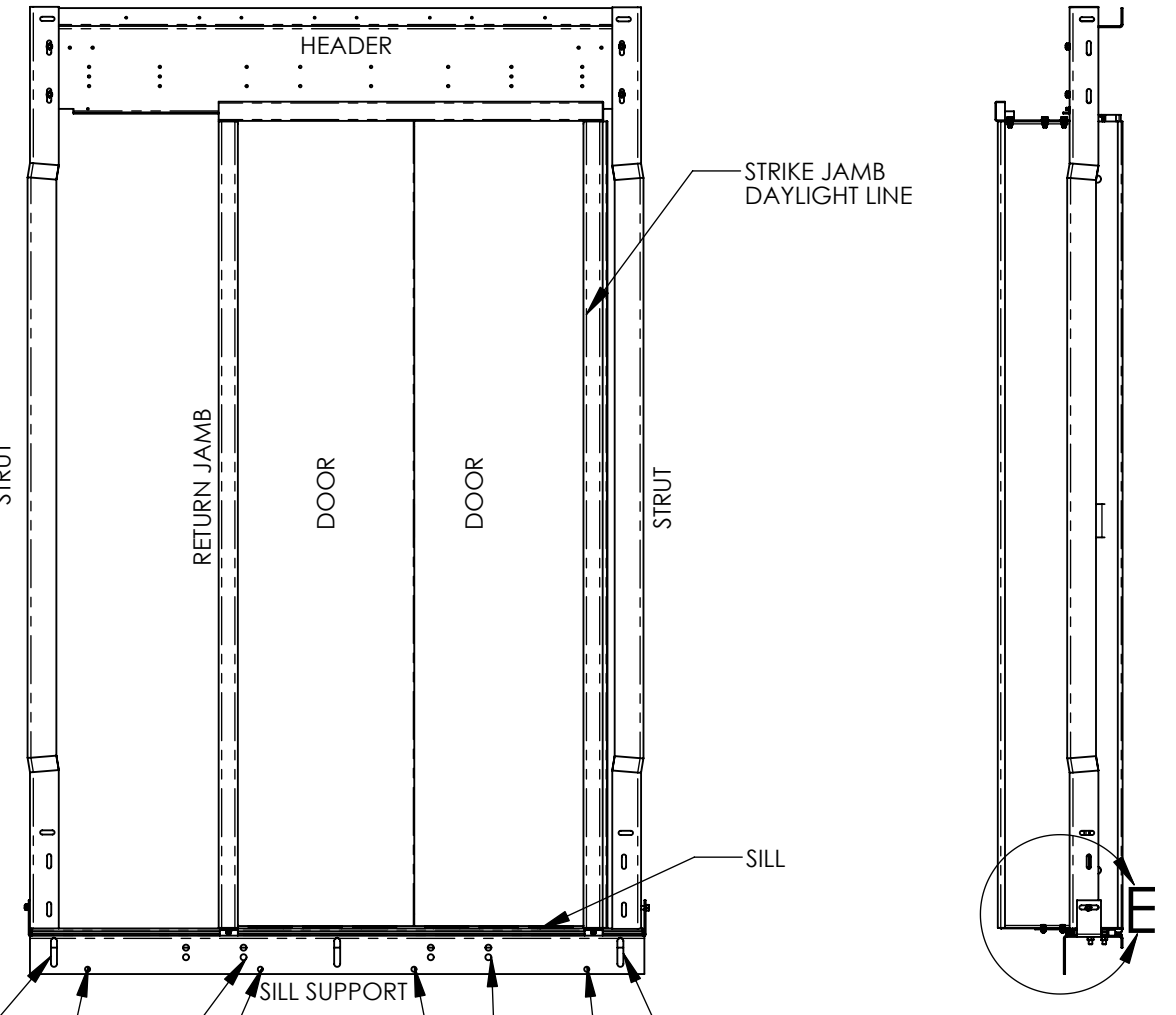

DOOR TOP CHANNEL DETAIL

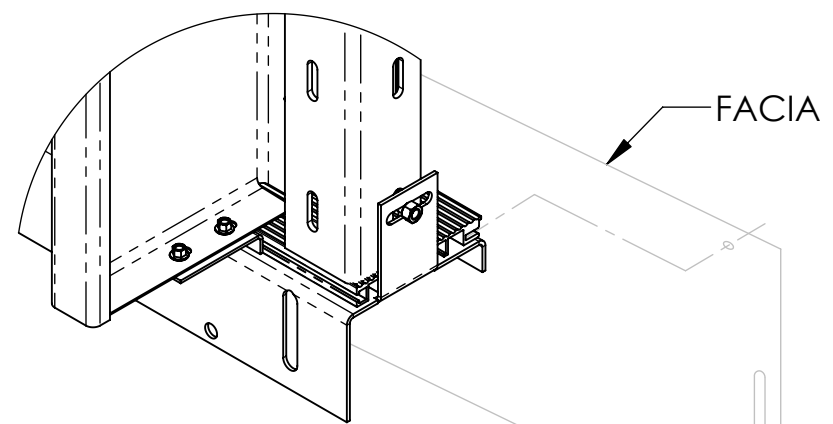

DETAIL D  
SCALE 1 : 6

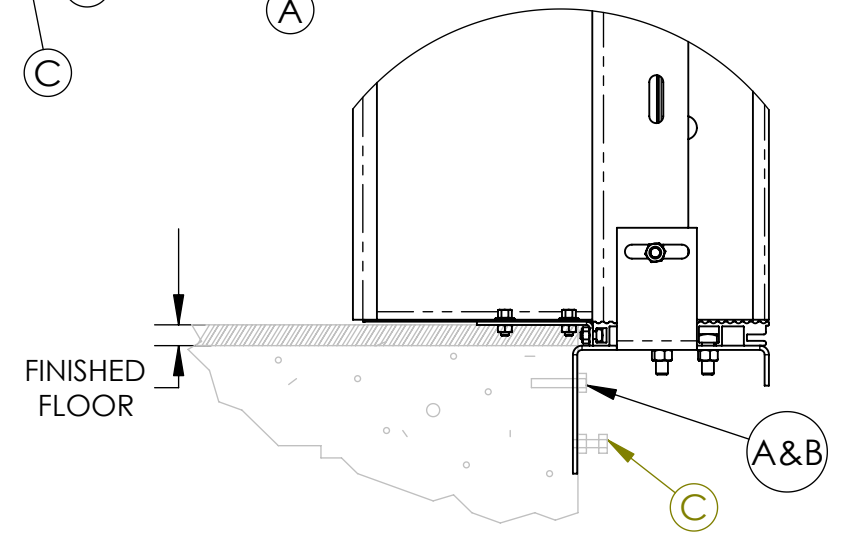
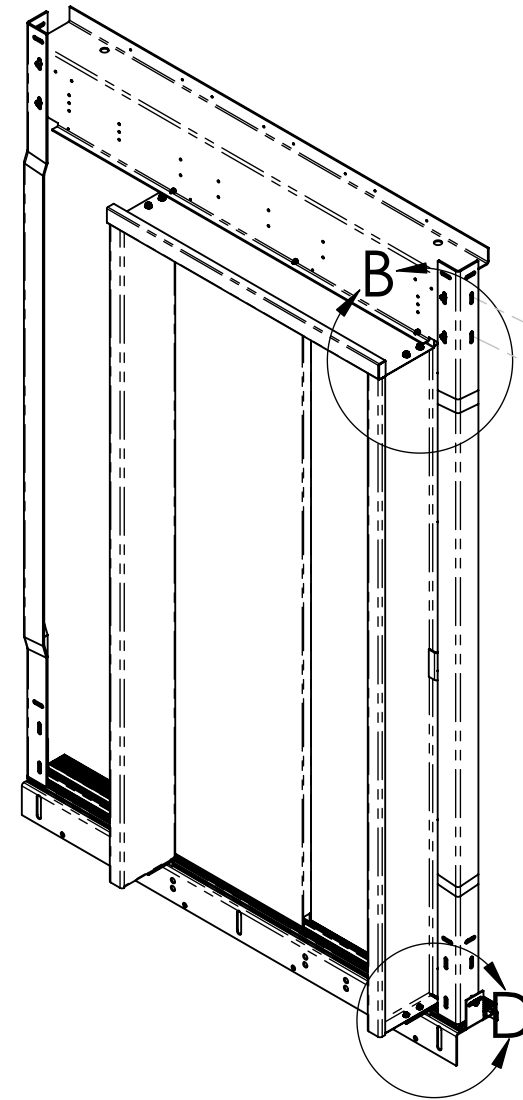

DETAIL E  
SCALE 1 : 6

DO NOT SCALE DRAWING		UNLESS OTHERWISE SPECIFIED:	MATERIAL	NAME	DATE	TITLE:	DWG. NO.	REV
<small>PROPRIETARY AND CONFIDENTIAL THE INFORMATION CONTAINED IN THIS DRAWING IS THE SOLE PROPERTY OF ELEVATOR SOLUTIONS INTERNATIONAL INC. ANY REPRODUCTION IN PART OR AS A WHOLE WITHOUT THE WRITTEN PERMISSION OF ELEVATOR SOLUTIONS INTERNATIONAL INC. IS PROHIBITED.</small>		<small>DIMENSIONS ARE IN INCHES TOLERANCES: FRACTIONAL: ±.01 ANGULAR: MACH ±.1 BEND ±1 TWO PLACE DECIMAL ±.005 THREE PLACE DECIMAL ±.0005</small>		KHL	2/5/2007	<b>2SPD ENTRANCE ES1a</b>	<b>D45352</b>	
				MODIFIED	klewis 4/25/2007		ELEVATOR SOLUTIONS INTERNATIONAL INC. ARKANSAS CITY, KS	
				O:\SOLID WORKS\D4500\		B SCALE: 1:20 WEIGHT: 356.888 SHEET 1 OF 1		