

DESCRIPTION	PLACE	QUANTITY
1/4" SQ	SILL TO "JAMB TO SILL BRACKET"	2
1/4" TRUSS	HEADER TO HEAD JAMB	3
5/16" DRIVE STUD	JAMB TO "JAMB TO SILL BRACKET"	4
3/8" WIZ	FRAME TO HEAD JAMB	6
3/8" WIZ	STRUT TO SILL SUPPORT	2
3/8" WIZ	STRUT TO HEADER	4
3/8" SQ	SILL TO SILL SUPPORT	4
ANCHOR FOR ADJUSTMENT	A	2
ANCHOR	B	2
JACK BOLT 3/8" W/NUT	C	4

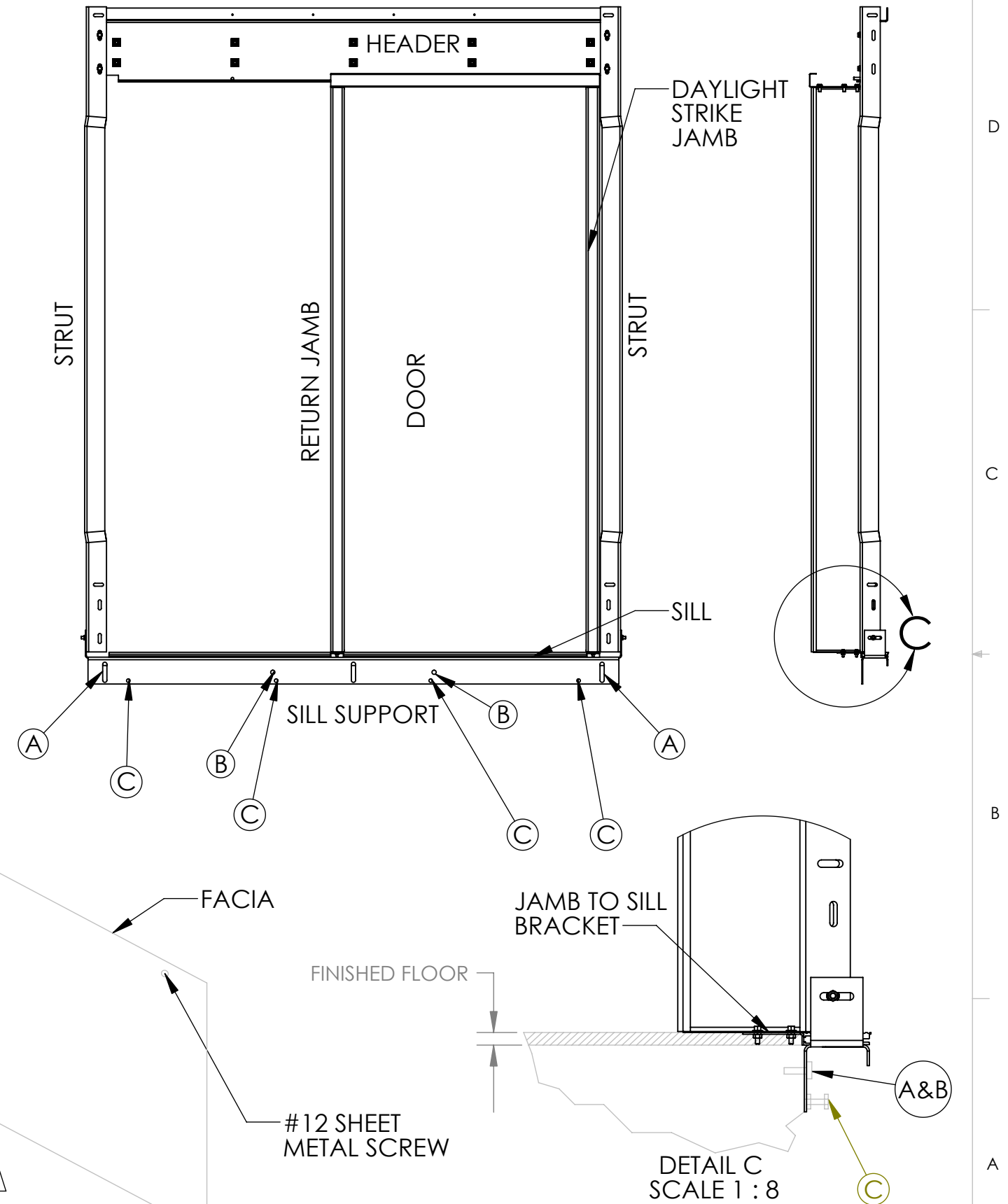
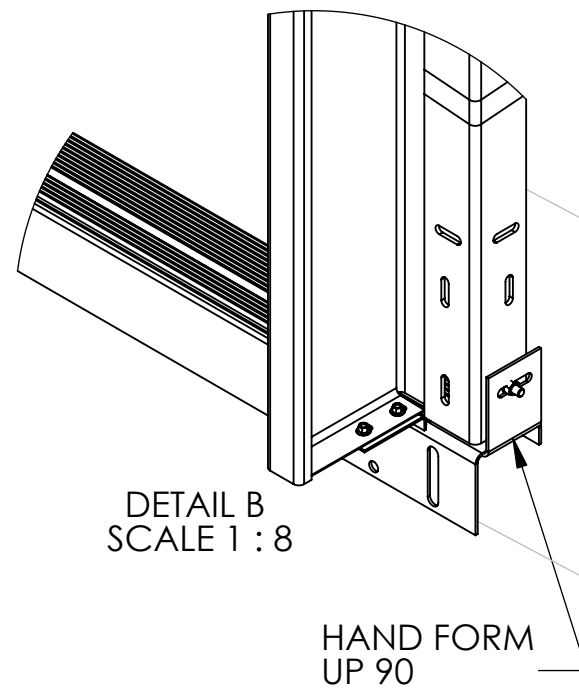
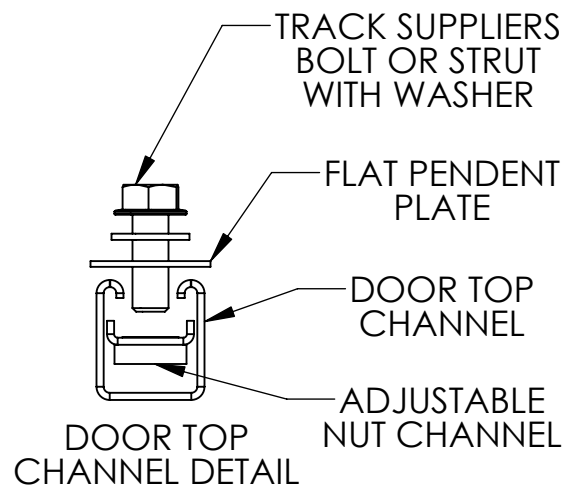
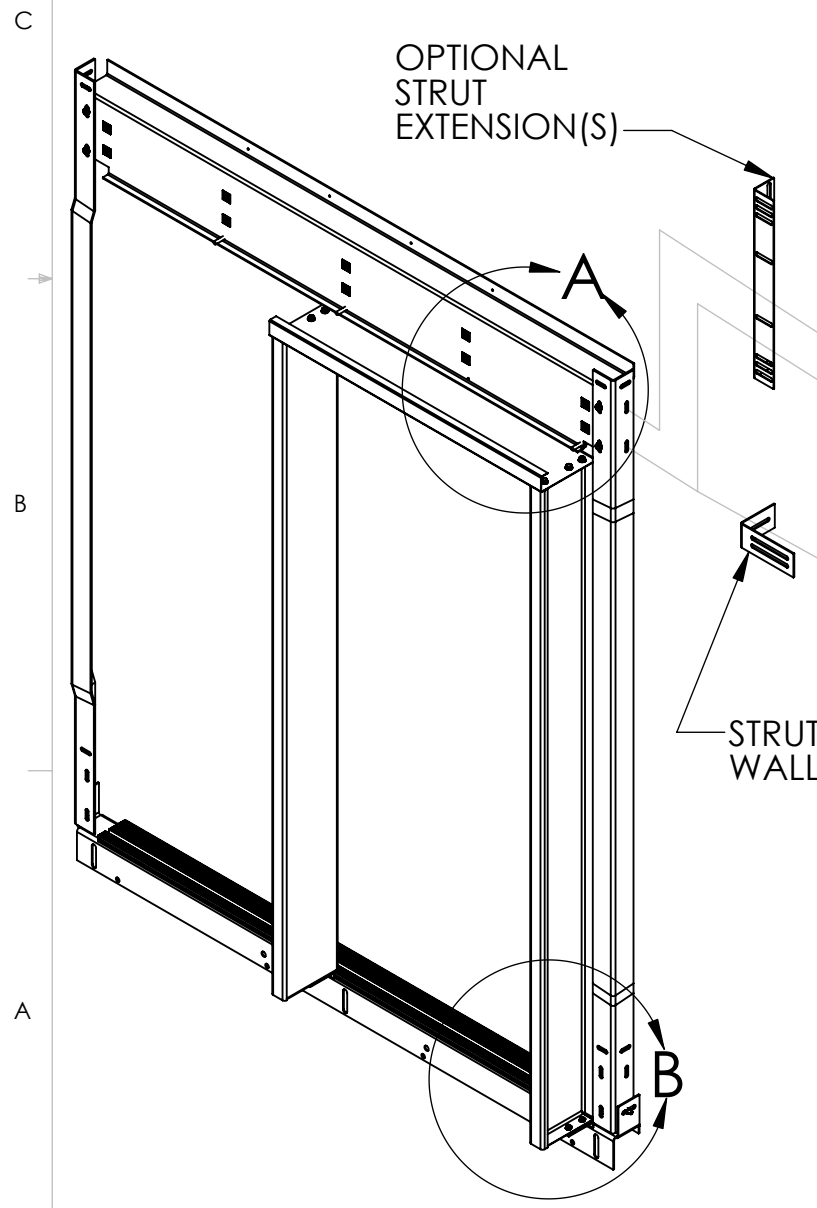
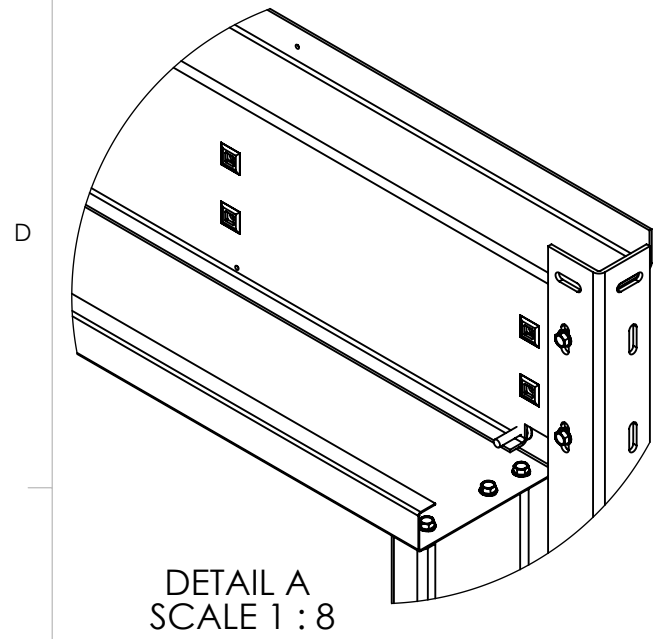

DO NOT SCALE DRAWING	UNLESS OTHERWISE SPECIFIED:	MATERIAL
PROPRIETARY AND CONFIDENTIAL THE INFORMATION CONTAINED IN THIS DRAWING IS THE SOLE PROPERTY OF ELEVATOR SOLUTIONS INTERNATIONAL INC. ANY REPRODUCTION IN PART OR AS A WHOLE WITHOUT THE WRITTEN PERMISSION OF ELEVATOR SOLUTIONS INTERNATIONAL INC. IS PROHIBITED.	DIMENSIONS ARE IN INCHES TOLERANCES: FRACTIONAL: ±.01 ANGULAR: MACH ±.1 BEND ±1 TWO PLACE DECIMAL ±.005 THREE PLACE DECIMAL ±.0005	

NAME	DATE	SINGLE SLIDE ENTRANCE ES1a
DRAWN KHL	6/18/2007	
MODIFIED klewis	6/25/2007	
O:\SOLID WORKS\D4500\		

SCALE: 1:20	WEIGHT: 194.503	SHEET 1 OF 1
-------------	-----------------	--------------

DWG. NO.	REV
D45478	
ELEVATOR SOLUTIONS INTERNATIONAL INC.	
ARKANSAS CITY, KS	